



moview
UPHOLDING A VISION.

tvmount

Product Number MDSL-F

double swing with lock

Supports Flat Panels up to 37" or 30 lbs.



Product features:

- Wide range VESA plate with a variety of fasteners and spacers to accommodate most flat panels
- Secure storage latch and compression bumpers for mobile applications
- Compact preassembled design for a simple installation
- Wide angle 180° + pan on a 19.000" extendable armature for versatile viewing angles
- Perfect for RV and Marine applications!

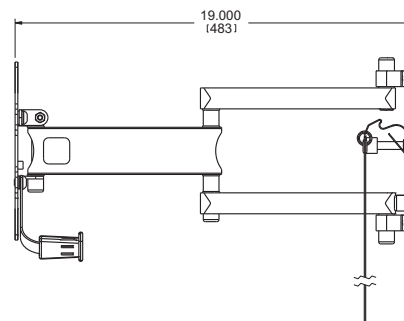
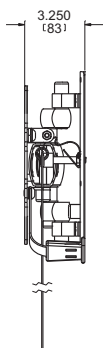
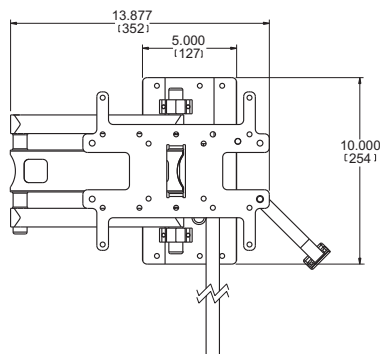

Product specifications:

Model: MDSL-F

**10 Year Warranty - No Assembly Required
Designed, Engineered, and Manufactured in USA**

	ENGLISH	(METRIC)
COMMON SCREEN SIZES:	23"-37"	(58.4cm - 94.0cm)
MAX LOAD:	30lbs	(13.6kg)
HOLE PATTERN RANGE: (VESA)	3 X 3", 4 X 4", 4 X 7-7/8", 7-7/8 X 7-7/8"	(75 X 75mm, 100 X 100mm 100 X 200mm, 200 X 200mm)
DIMENSIONS:	13-7/8" W X 10" H X 3-1/4" D	(35.2 W X 25.4 H X 8.3 D cm)
SHIPPING WEIGHT:	6.3lbs	(2.9kg)

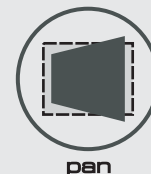

pan